

EXAMPLE:
 RED FIBERS GO TO LEG "B1"
 WHITE FIBERS GO TO LEG "B2"
 BLUE FIBERS GO TO LEG "B3"
 GREEN FIBERS GO TO LEG "B4"

CUSTOMER DEFINED FIBER DIVISION	
PERCENTS [%] OF FIBERS	FIBER DIVISION
	FROM LEG "A" GO TO LEG "B1"
	FROM LEG "A" GO TO LEG "B2"
	FROM LEG "A" GO TO LEG "B3"

	FROM LEG "A" GO TO LEG "BN"

EXAMPLE:
 25% FIBERS FROM LEG "A" GO TO LEG "B1"
 25% FIBERS FROM LEG "A" GO TO LEG "B2"
 25% FIBERS FROM LEG "A" GO TO LEG "B3"
 25% FIBERS FROM LEG "A" GO TO LEG "B4"

CODE EXPLANATION

MLB8 - 1.5 / 1200 / [] / 7 R - SMA - GM

ACTIVE DIAMETER "AD" IN [MM] CUSTOMER DEFINED MAX. 2MM

LENGTH "L1" IN [MM] CUSTOMER DEFINED

RANDOMIZATION

	TYPE "ZR"
CR	TYPE "CR"
CD	CUSTOMER

NUMBER OF LEGS CUSTOMER DEFINED

FIBERS JACKET ARE REMOVED

	NOT REMOVED
R	REMOVED

JACKETING TYPE

P	PVC
GM	GALVANIZED STEEL PVC MONOCOIL
SS	STAINLESS STEEL
S	SILICONE
CD	CUSTOMER DEFINED

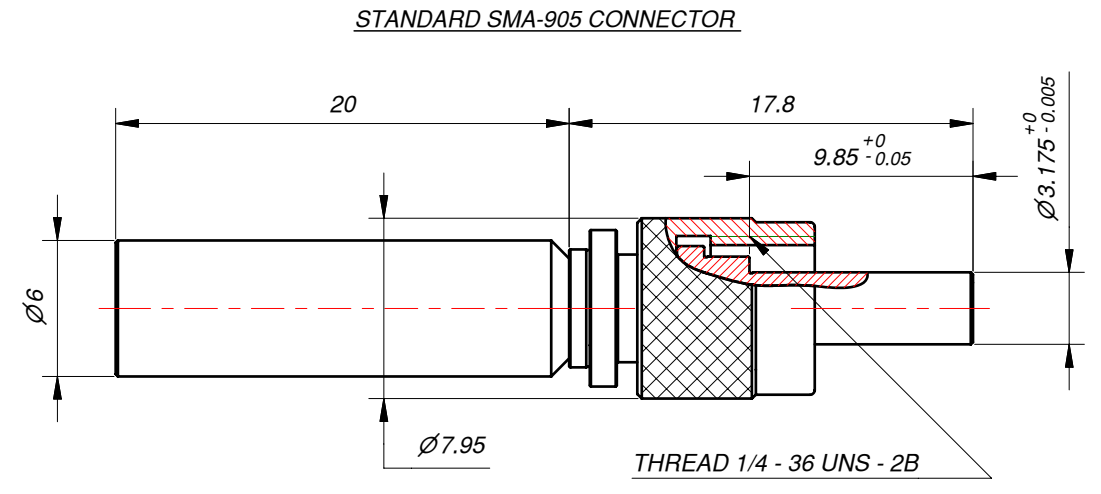

- MULTIMODE OPTICAL FIBER SELECTION:**
- POSSIBLE FIBER TRANSMISSION IN THE RANGE:
 - ZLUV 180 - 1200 NM (NA=0.22; 0.26; LOWER NA ON REQUEST).
 - ZLWF 400 - 2200 NM (NA=0.22; 0.26; LOWER NA ON REQUEST).
 - ZLPUV 250 - 1100 NM (NA=0.37).
 - ZLPWF 400 - 2200 NM (NA=0.37).
 - STRESS PROOF LOAD 100KPSI.
 - FOR OTHER FIBER PARAMETERS PLEASE LOOK FIBER CATALOG.

TITLE: MLB8 - FIBER BUNDLE MULTI LEG - BUNDLE		
SIZE: A2	DRAWING NO.: MLB8-001-00	REV.: A
FILE NAME: MLB8-001-00.idw	ITEM NO.:	
COMPANY: Z-LIGHT, LTD.	CODE NO.:	
HOME PAGE: HTTP://WWW.Z-LIGHT.LV	ORDER NO.:	
SCALE: DO NOT SCALE	DIMENSIONS ARE IN MM	SHEET 1 OF 1